

Evaluating semi-empirical wave forecasting method CEM in the Strait of Hormuz

Mahmud Reza Abbasi ¹

¹ Physical Oceanography PhD, assistant professor of Imam Khamenei Marine Science and Technology, Zibakenar, Gilan, Iran; phys.ocean.abbasi@gmail.com

ARTICLE INFO

Article History:

Received: 28 Nov. 2019

Accepted: 11 Jun. 2020

Keywords:

Wind wave

Forecasting

CEM

Hormuz Strait

Numerical modeling

ABSTRACT

Wind waves are one of the most important phenomena that should be considered in coastal and offshore activities. They have many effects on coastal environments such as wave-induced erosion, sediment and pollution transport and even in the worst cases destruction the marine ecosystems. Therefore, knowing the wave characteristics is very important for environmental research. In this paper, the accuracy of CEM semi-empirical method in forecasting the wind-induced waves characteristics in the Strait of Hormuz (SOH) have been studied. Initially, the characteristics of the waves have been calculated by employing the CEM based on wind data from local synoptic stations. Then, the evaluating process have been done by comparing the forecasting values (wave heights and periods) of this method with same recorded value of wave buoys in the SOH. According to the performed study, the accuracy of semi-empirical method in forecasting wave characteristics were in close agreement with measurements values and the SMB method is suitable for determining the wave characteristics in this area. The results show that there is a good correlation coefficient between observations and forecasting data in the CEM and the CEM method has a very small bias error. So, this method is suitable for determination the wave characteristics in this area.

1. Introduction

Knowledge of the characteristics of wind-induced waves is one of the most important issue for every environmental activity on the coast, both in the land and in Water. Damages caused by the waves are as deforming the coasts by erosion, sediment transport and causing changes in natural ecosystems. Since practically the continues monitoring and complete coverage of coasts are generally limited due to the huge costs, a compatible method for determining the wave characteristics is required to ensuring the prosperity of an environmental monitoring system. In order to calculate the waves characteristic, many semi-empirical methods such as SMB [1], CEM [2] and SPM [3], numerical models such as Mike 21[4], Wavewatch [5], SWAN [6] and WAM [7] and soft computation methods such as ANN [8], Regression tree[9], fuzzy inference system [10,11] and genetic algorithm [12] have been employed.

Considering the SOH as a habitat for mangrove forests and the presence of environmentally sensitive areas in this area and the impact of sea waves on these environments, accurate knowledge of wave characteristics is very important and very essential for marine researchers. Because of the lake of long-term field wave data and the high cost of field

measurements, using the numerical methods and experimental models is preferred to obtain the wave characteristics. Semi-empirical methods because of their simplicity and low cost, the coastal engineers and marine institutions generally use these methods.

Previously many wave studies in different Iranian coastal regions by using various methods have been done [13-16]. In this paper, one of the best significant semi-empirical methods in calculation the wave characteristics known as the CEM has been used to forecast wave characteristics in the SOH.

2. Materials and Methods

2.1. Study area

The SOH as a connectional canal connects the Persian Gulf to the Oman Sea have been located between 24-28° N in latitude and 51-56° E in longitude (Fig.1). This narrow marine gate with 280 km east-west length and 56 km north-south width is one of the most important waterways in the world. Its depth varies between 40m near the Iranian coasts on the north to 200m near the Omani coasts on the Musandam Peninsula on the south [17]. Approximately 90% of the Persian Gulf oil or on the other hand 40% world's oil exports through this waterway [18,19].

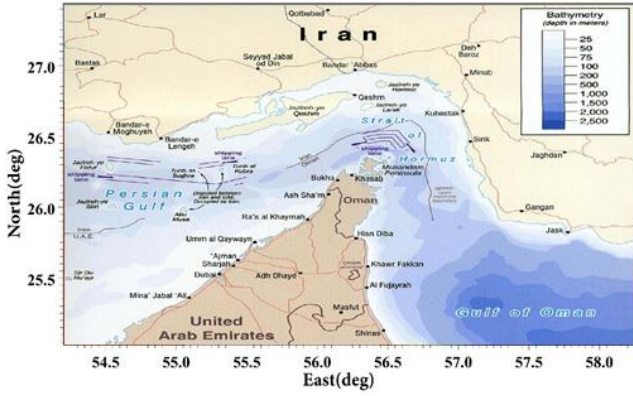

Figure 1. Bathymetry and neighboring regions of SOH

2.2. CEM method

The semi-empirical method CEM is the newest method in wave prediction. In this method the length of fetch in a given direction is determined with plotting through 30 radii (with intervals of 1 Degree) on both sides of the wind direction of blowing from the studied point to the first point of intersection with the coastline [20]. The mean value of these radii is the fetch length.

In semi-empirical methods, wave height and period are calculated based on wind speed, fetch length and wind duration. To determine the wind duration, we used definition of constant wind. In this method the continuity time of wind in the *i*th-hour is equal to the number of preceding consecutive and acceptable previous hours that should satisfy the following circumstances:

$$|U_i - \bar{U}| < 2.5 \text{ m/s} \quad (1)$$

$$|D_i - \bar{D}| < 15^\circ \quad (2)$$

\bar{U} and \bar{D} are the mean of preceding consecutive and acceptable hourly wind speed and direction, respectively. U_i and D_i are the speed and direction of the wind in the *i*th hour of the data. The minimum wind duration is computed as follows:

$$t_{min} = 77.23 \frac{F^{0.67}}{U_{10}^{0.34} g^{0.33}} \quad (3)$$

in which F is the fetch length in meters, U_{10} is the wind speed at a height of 10 meters from the sea surface in meters per second.

For the fetch limited case, the non-dimensional forecast equations for significant wave height and peak period are defined as:

$$H_s = 4.13 \times 10^{-2} \times \sqrt{\frac{U_*^2 F}{g}} \quad (4)$$

$$T_p = \frac{1}{2.727} \left(\frac{U_* F}{g^2} \right)^{1/3} \quad (5)$$

Where U_* is the shear velocity and estimated from the following equation:

$$U_* = U_{10} (C_d)^{0.5} \quad (6)$$

where C_d is the wind drag coefficient, which is calculated as:

$$C_d = 0.001(1.1 + 0.035U_{10}) \quad (7)$$

But if the wind duration was not greater than the minimum necessary duration, the duration limited condition is considered and the equivalent fetch length, significant wave height and peak period are computed as below:

$$\frac{gF}{U_*^2} = 5.23 \times 10^{-3} \left(\frac{gt}{U_*^2} \right)^{1.5} \quad (8)$$

$$H_s = 2.115 \times 10^2 \times \sqrt{\frac{U_*^2}{g}} \quad (9)$$

$$T_p = 2.398 \times \left(\frac{U_*}{g} \right) \quad (10)$$

2.3. Wind and wave data

In this study the required wind speed data for forecasting wave height and period in given area were gathered from European Centre for Medium-Range Weather Forecast (ECMWF) database. These data consist of two wind components (u and v) have $0.25^*0.25$ and 6-hour interval spatial and temporal resolution, respectively. Before applying the coastal area wind data in CEM equations, the correction was carried out by the nearest coastal wind measurement synoptic station (Qeshm Island) (Figure 2).

The wave information including significant wave height and mean wave period were gathered from wave buoy near the northern coast of SOH from 1 July 2002 until 31 August 2002. These data include 1536 discrete records. This Buoy was located by the consultant engineering corporation in the longitude of 55.55° east and the latitude of 26.6° north (Figure 2).

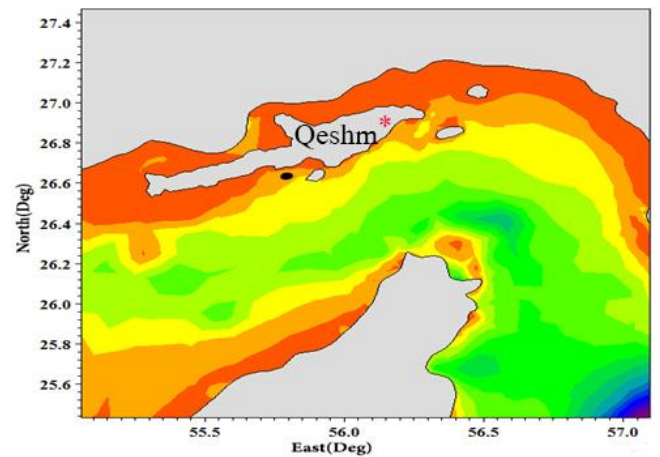

Figure 2. Strait of Hormuz. wave buoy location (black dot), nearest synoptic station (red star).

In this study, in order to evaluating the accuracy of the CEM method and comparing the results of the forecasted wave height with the measurement values,

statistical parameters such as the scatter index (SI), correlation coefficient (CC), root mean square error (RMSE) and bias (Bias) were used as follows:

$$Bias = \bar{x} - \bar{y} \tag{11}$$

$$CC = \frac{\sum_{i=1}^n (x_i - \bar{x}) \times (y_i - \bar{y})}{\sqrt{\sum_{i=1}^n (x_i - \bar{x})^2 \sum_{i=1}^n (y_i - \bar{y})^2}} \tag{12}$$

$$RMSE = \sqrt{\frac{\sum_i (x_i - y_i)^2}{n}} \tag{13}$$

$$SI = \frac{\sqrt{\frac{1}{n} \sum_i (x_i - y_i)^2}}{\bar{x}} \tag{14}$$

Where x, y and n are the observed parameter, the forecasted parameters and the number of observed, respectively.

3. Results and Discussion

In this study, the capabilities of semi-empirical wave forecasting method CEM in forecasting the wave characteristics in the Strait of Hormuz was examined. For this purpose, the scatter plots and time series plots of wave height, wave period and wave direction of CEM and buoy for comparison between them are showed in figures 3,4. Also, four statistical error parameters based on 11-14 equations were computed in order to assess the quantity comparisons between of two data sources (CEM and buoy).

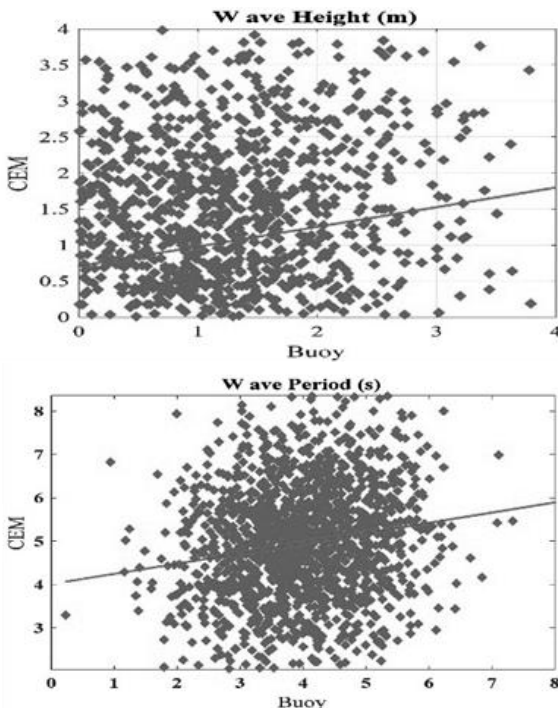

Figure 3. Scatter plot comparison of wave height(up) and wave period(down) from Buoy and CEM

As seen from figure 3, wave height Scatter plot presents a good agreement between the CEM method data and buoy data and the correlation coefficient is %65 for this wave parameter. But for wave period this correlation is not seen as good as wave height and correlation coefficient is %25. The CEM method underestimated both two wave characteristics

at SOH region. The bias values are -0.25m and -1.04s for wave height and period, respectively. Also, the CEM wave height forecasting has the lower RMSE value (0.43m) than wave period RMSE (2.25s).

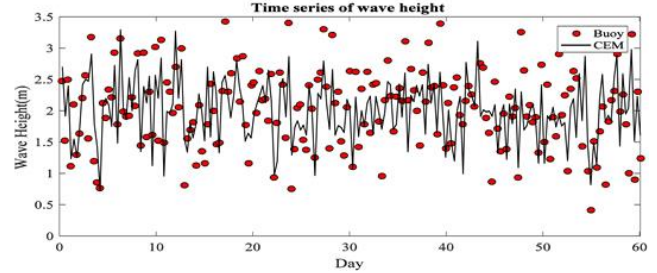

Figure 4. Time series comparison of wave height from Buoy and CEM

Generally, the forecasted and field measured time series of wave height matches but buoy data shows a slight underestimation of this parameter (Fig. 4).

In order to check correctly the directions of the forecasts Wave by semi-empirical methods, the wave roses of SOH buoy and CEM method in time study are presented in Fig. 5.

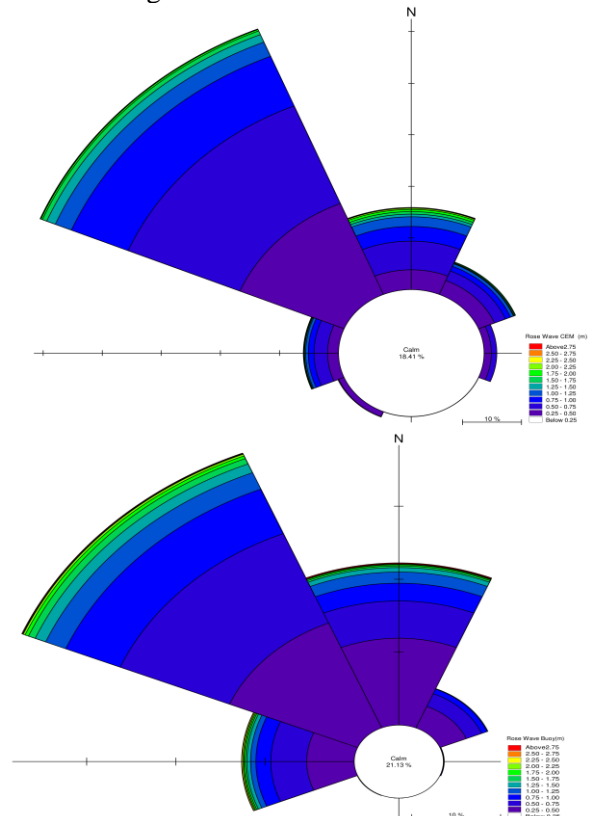

Fig. 5. Wave roses from buoy data(up) and CEM (down)

By comparing the wave roses of the CEM and observed data as shown in Fig. 5, although the two wave roses are in good agreement in terms of overall shape and dominant wave directions, but they differ in terms of the frequency of waves occurring in different directions. As can be seen in Fig. 5, the first dominant wave direction is at the northwest direction whose abundances are %65 and %48 for CEM and buoy rose waves, respectively. However, CEM wind rose shows lower value in high speed winds than buoy wave rose. It is worth noting that the difference between two wave roses in calm conditions reaches to its maximum value of %3. The reason of this difference is that when the wind speed is zero, the

semi-empirical methods estimate the wave height equal to zero.

For quantitation the CEM model performance the model wave height and period results were comprised with the same local buoy data by calculating the statistical parameters which are presented in table 1.

Table 1. wave characteristics error forecasting by CEM

statistical parameters	Wave Height(m)	Wave Period(s)
Bias	-0.25	-1.04
Correlation Coefficient (%)	65	25
Root Mean Square Error	0.43	2.25
Scatter Index (%)	66	45

4. Conclusions

In the present study, firstly, the characteristics of the waves in Strait of Hormuz forecasted using semi-empirical method CEM and then by comparison between the forecasted value and observed data from local buoy, the errors of this method were determined. The most important results of this study are as follows:

- The CEM method underestimated the wave height and period forecasting in this area.
- By comparison the CEM and buoy wave roses it was showed that the prevailing forecasted wave direction by CEM is in northwest direction in this area in which has a good agreement with buoy data.
- The correlation between the forecasted wave height and observed data was better than the wave period.
- According to the results it seems that the main cause of the error of the semi-empirical method in this region is inappropriate wind input data due to lack of required information in the desired area.
- Due to the error generated by semi-empirical method, CEM is not a suitable method for determining the wave period in this area.

5. References

1- US Army., (2003). *Coastal Engineering Manual, Chapter II-2, Meteorology and Wave Climate, Engineer Manual*. 1110-2-1100. U.S. Army Corps of Engineers, Washington, DC.

2- US Army., (1984), *Shore Protection Manual*. 4th ed. 2 vols. U.S. Army Engineer Waterways Experiment Station, U.S. Government Printing Office, Washington, DC.

3- Sverdrup, H. U., and Munk, W. H., (1947), *Wind sea and swell: theory of relations for forecasting*. Publication 601, U.S. Navy Hydrographic office, Washington, DC.

4- Tolman, H. L., (1991), *A third-generation model for wind waves on slowly varying, unsteady and inhomogeneous depths and currents*. Journal of Physical Oceanography 21, p.782-797.

5- Booij, N., Ris, R. C., and Holthuijsen, L. H., (1999), *A third-generation wave model for coastal regions. 1. Model Description and validation*. Journal of Geophysical Research 104, p.7649-7666.

6- Komen, G. J., Cavaleri, L., Donelan, M., Hasselmann, K., Hasselmann, S., and Janssen, P.A.E.M., (1994), *Dynamics and modeling of ocean waves*. Cambridge University Press.

7- DHI Water & Environment, 2004. *MIKE 21 spectral wave module*. Scientific documentation.

8- Moeini, M. H., Etemad-Shahidi, A., and Chegini, V., (2010), *Wave modeling and extreme value analysis off the northern coast of the Persian Gulf*. Applied Ocean Research 32, p.209-218.

9- Moeini, M. H., and Etemad-Shahidi, A., (2007), *Application of two numerical models for wave hindcasting in Lake Erie*. Applied Ocean Research 29, p.137-145.

10- Rogers, W. E., Kaihatu, J. M., Hsu, L., Jensen, R. E., Dykes, J. D., and Holland, K. T., (2007), *Forecasting and hindcasting waves with the SWAN model in the Southern California Bight*. Coastal Engineering 54, p.1-15.

11- Signell, R. P., Carniel, S., Cavaleri, L., Chiggiato, J., Doyle, J., Pullen, J., and Sclavo, M., (2005), *Assessment of wind quality for oceanographic modelling in semi-enclosed basins*. Journal of Marine Systems 53, p.217-33.

12- Caliskan, h., Valle-Levinson, A., (2008). *Wind-wave transformation in an elongated bay*. Continental shelf research 28, p.1702-1710.

13- Rusu, E., Pilar, P., Guedes Soares, C., (2008), *Evaluation of the wave conditions in Madeira Archipelago with spectral models*. Ocean Engineering 35, p.1357-1371.

14- Bolaños-Sanchez, R., Sanchez-Arcilla, A., Cateura, J., (2007), *Evaluation of two atmospheric models or wind-wave modeling in the NW Mediterranean*. Journal of Marine Systems 65, p.336-353.